



## Marking a Major Milestone With a New Blue and Orange Exhibit

### *Ever Changing, Yet the Same: OPRF High School at 150*

The new first-floor featured exhibit *Ever Changing, Yet the Same: OPRF High School at 150* will be opening to the public at Oak Park River Forest Museum on Thursday Sept. 21 just in time for the Homecoming Football Game the next night, kicking off a year-long celebration of the Sesquicentennial of one of the central institutions of our sister villages.

The exhibit will feature memorabilia, yearbooks, school spirit wear from throughout the decades, photos, dance bids, scrapbooks, and a wide range of other artifacts that will help tell the rich story of Oak Park and River

Forest High School, which enrolled its first students in 1873 in a classroom at Lake and Forest and graduated its first three alumni in 1877.

Of course, the one million square foot facility bordered by Lake Street, Scoville Avenue, Erie Street, and Linden Avenue now educates thousands of students each year and has tens of thousands of alumni who have made their mark in a wide variety of professions and walks of life. While it is impossible to tell every important story, the exhibit will curate milestones and moments along the way as the institution grew from a village high school into an elite high school and finally into the diverse, high-quality

educational institution of today. Visitors will be invited to find out more about some of OPRF's notable graduates and add their own stories to a card catalog that used to be located in the OPRF High School Library.

The exhibit is being developed with a grant from the Oak Park and River Forest High School Alumni Association and in partnership with the Sesquicentennial Steering Committee, composed of faculty, staff, residents, students and alumni. The exhibit will feature a large timeline of OPRF High School history on one wall and colorful banners which will break down the "big picture" of 150 years of tradition and innovation into three, 50-year sections. Extra sets of these banners will be used as traveling exhibits in the community over the next two years. And, of course, a large collection of memorabilia from the OPRF High School Archives (loaned to OPRF Museum in 2021) and from the Historical Society's collection will show just how much the Huskies have changed through the decades and yet how entrenched traditions still echo from earlier decades and impact students of the 2020s.



*Official logo of Oak Park and River Forest High School's Sesquicentennial Celebration*

OPRF senior Anna Miller has been working diligently this summer as a paid intern for the project thanks to OPRF Alumni Association funding, which is also supporting graphic and design work by Rich Faron, a 1977 OPRF graduate and owner of Museum Explorer, Inc., a Berwyn-based firm that has done work for museums large and small including the Chicago History Museum, Evanston Historical Society, and Lincoln Park Zoo.

"It has been exciting for me this year serving on the OPRF Sesquicentennial Steering Committee and as a member of the Exhibit and Events Committee," said Executive Director Frank Lipo. "While not a graduate myself, my wife and three daughters are alumni and I have seen the tremendous impact on the community of the high school. It is an honor to try to tell some of these stories at OPRF Museum. I have been especially excited to work with Anna Miller, who is bringing her perspective and skills as assistant curator of the exhibit, and Operations Manager Rachel Berlinski, who is pulling it all together."

"Ever Changing, Yet the Same ..." is a line from the Oak Park Hymn, sometimes called the Alma Mater. "We thought that line really captures the essence of an institution like OPRF High School (and most other high schools, for that matter)," said Lipo. "Continuity and change are interwoven through each school's history with sports and clubs and social life changing over time, but also each new cohort of students blending their unique skills and perspectives to showcase the institution."

While many in the community know aspects of the history of the school, there are sure to be stories

that are new or fresh takes on oft-told stories. For instance:

- Have you heard of the Experimental Program (commonly shortened to XP)?
- Did you know that a streaker once ran across the OPRF football field at a Memorial Day assembly in 1979 and was lampooned by a legendary Chicago columnist?
- Did you know that between 1975 and 1985, each day at lunch a movie was shown in 20-minute increments in Little Theater?



Many traditions at OPRFHS span a century or more, as illustrated by these photos of the Girls Basketball teams from 1900 (above) and from 2000 (below)



- Did you know that students who lived in Elmwood Park attended OPRF High School in the 1950s on a tuition basis while Elmwood Park High School was being built?
- Did you know that a successful River Forest Referendum in the 1940s caused River Forest to secede from OPRF High School for a few years?

Beginning October 4, we will be hosting "A Night at the Museum" gallery talks at 7p.m. on the first Wednesday of each month. October 4 will also double as a formal Grand Opening of our

new exhibit, with special guests expected.

Contact us if you would like to help us organize a presentation about some aspect of OPRF—a state championship you participated in, a club or other activity that shaped your life, etc.

Special events are planned throughout the year and residents, students and alumni are being challenged to collectively accumulate at least 150,000 hours of community service by the 2024 Commencement in May. (See the QR code on the back cover to find out more.)

Give us a call at 708-848-6755 if you have some memorabilia or memories to share!



Field Trip: Tales from the Fields Research Center

## Operations Manager Earns the Title of "Small Museum Pro!"

By Rachel Berlinski, Operations Manager

I have been absent from the past few newsletters, but some incredible volunteers have filled in for me with articles about their phenomenal findings in the Fields Research Center.

In addition to helping volunteers, researchers, and visitors, I've also had the luck and pleasure to pursue further education. For the past year, I have

field like exhibit curation, exhibit installation, gathering and handling artifacts, managing memberships and donations, leading tours, coordinating field trips, coordinating volunteers, running events, helping researchers, and the list goes on and on. I have had the distinct pleasure of being able to do all of the above!

With the experience I've gained over my six-year tenure at OPRF Museum, I've already been able to apply much of the information I learned in the "Small Museum Pro" program. I've especially appreciated the opportunity to work virtually with colleagues from other small institutions throughout the country through these online classes. I am honored to have the opportunity not only to learn more about the field of public history and museum work, but to apply that knowledge in a meaningful way by sharing it with you all through OPRF Museum.

This summer and fall, I have the important challenge of putting into practice some of the tools I have learned about creating exhibits. Watch for more information and events related to our upcoming exhibit *Ever Changing, Yet the Same*, marking 150 years of history at Oak Park and River Forest High School.



been taking online classes for a certification program through the American Association for State and Local History (AASLH). After five courses on a variety of topics, I have earned a certificate as a "Small Museum Pro!"

AASLH is a national institution based in Nashville which supports historical organizations of all sizes through professional development and networking. With a handful of courses to choose from in the program, the path I chose covered exhibit planning and design, education programs, financial management, and leadership. Each of these topics relates to our day-to-day work at the museum. All the classes and topics have felt very familiar, yet all have been incredibly eye-opening too.

Small Museums come in all shapes and sizes, but one thing that defines those who work in a small museum is the necessity to work on all aspects of operation. In any of Chicago's esteemed downtown museums, there are separate staff members for each

### History Matters

© 2023

The Quarterly Newsletter of Oak Park River Forest Museum  
129 Lake Street, Oak Park, IL 60302 / Phone (708) 848-6755  
Published by The Historical Society of Oak Park & River  
Forest, P.O. Box 771, Oak Park, Illinois 60303-0771  
[oprfmuseum.org](http://oprfmuseum.org)

Executive Director: Frank Lipo  
Operations Manager: Rachel Berlinski

#### Officers

Fran Knechel, President Jack Norton, Treasurer  
Wendy Daniels, Vice President Mary Boyaris, Secretary

#### Board Members

Frank FioRito Ty Mayberry Joel Summy  
Jim Grogan Peggy Tuck Sinko Clyde Watkins  
Nancy Lynn Jennie Stevens

Editors: Pamela Lyons and Kurt Etchingham

We welcome your suggestions and comments. Please email us at: [oprhistorymatters@sbcglobal.net](mailto:oprhistorymatters@sbcglobal.net)

# The Candy Maker and the Cop

By Frank R. Fiorito, OPRF Museum Board Member

From police cars, to fire trucks, to trains and tow trucks, flashing lights grab our attention. They are a part of everyday life, certainly part of the urban landscape. The flashing lights on top of these vehicles are generally referred to as “Mars Lights,” a curious name that conjures up the soft glow of the red planet, but the name has a sweeter origin.

Minnesota-born candy magnate Franklin C. Mars and inventor Jeremiah D. Kennelly were not a pair likely to become acquaintances. It was their mutual interest in police work that brought the two men together in a collaboration that resulted in the development of the Mars Light.

Jeremiah “Jerry” D. Kennelly was the son of an Irish immigrant, Jeremiah E. Kennelly. In conversation with his son, the elder Kennelly shared many experiences he had during his 37-year career as a patrolman for the Chicago Police Department. Inspired, Jerry, formerly a machinist, joined the Oak Park Police Department. Skilled at working with machines, he became a motorcycle patrolman.

Oak Park had purchased its first motorcycles as early as 1910. The motorcycle was the latest tool in law enforcement, especially considering the growing number of motor vehicles now passing through the village, some often recklessly. Motorcycle patrols provided new opportunities for those who were mechanically inclined and not afraid of dealing with new hazards.

As a new patrolman, Jerry soon became known to the public, heralded in newspaper accounts about some of his exploits. For instance:

- In August 1923, he stopped a truck loaded with suspicious barrels. His hunch was right.

The barrels contained 250 gallons of illegal beer, outlawed under Prohibition, beer soon to be redirected to the sewers.

- In December 1923, while in “hasty pursuit” of a man with a gun in an automobile driving down Oak Park Avenue, Jerry was forced to swerve when another car crossed his path at Adams Street. Hitting the curb, Jerry went airborne and suffered multiple bumps and bruises requiring treatment at West Suburban Hospital and days recuperating at home.

- In July of 1924, Jerry and a fellow motorcycle patrolman responded to a robbery at 509 Fair Oaks Avenue. Spotting the likely suspects in the alley between Fair Oaks and East Avenue just north of Chicago Avenue, the officers ordered them to halt for questioning. The suspects responded with gunfire and Jerry was shot in the face, but as he fell to the ground, he opened fire managing to hit one of them with two bullets. As the other suspect took off with police in pursuit, Jerry mounted his motorcycle and rode to West Suburban Hospital, hand to his wounded cheek and covered with blood.

- Recovered and back on the job, Jerry wouldn’t escape 1924 until one more encounter with an automobile traveling at high speed. That October, he was sideswiped at Washington Boulevard and Humphrey Avenue, resulting in deep cuts to both of his legs. Once again, Jerry headed to West Suburban Hospital for treatment.

Injuries sustained at the hands of lawbreakers were risks a patrolman couldn’t fully control. Instead, Jerry decided to focus on minimizing the

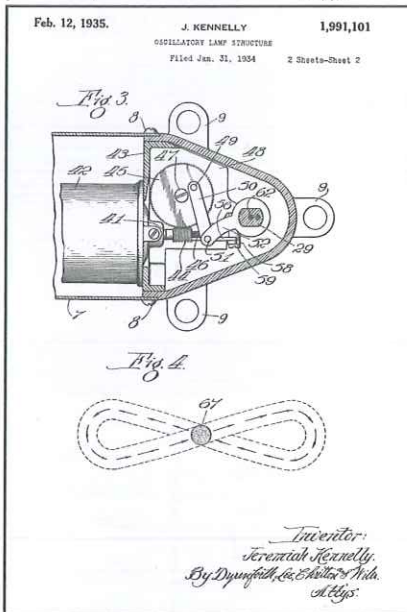
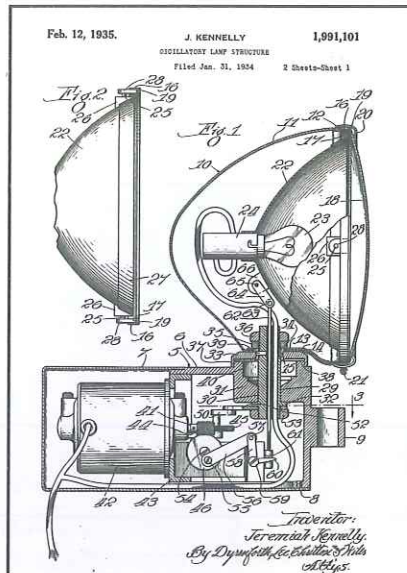

Kennelly submitted the above drawings of his invention as part of his application to the United States Patent Office.

controllable risks, namely accidents caused by the law abiding, but unaware, public. Officer Kennelly started to put the skills he had learned as a machinist to work on a solution.

Early police cars looked the same as other cars on the road. They were often limited to open top cars so



*Jerry Kennelly's 1922 Oak Park Police Department photo*

the public could see the uniformed officers. If the public wasn't observant, civilians often got in the way. This posed a significant danger to officers in pursuit. In the early 1900s, emergency signals to alert the public were limited to bells, horns, and sirens, but often there was no signal used at all.

Early sirens posed several problems. They required some means of power via hand crank, electric motor, or even direct contact with the car's tires. Their sound could be muffled or confused with other ambient noise. Their weight made their use impractical on a motorcycle.

Lights were added, but these were set in a fixed position and limited in attracting attention especially during the daylight hours. Jerry's innovation was to put the light in motion.

Taking an invention from concept to patent is an expensive process. Fortunately, Jerry had an acquaintance who was very interested in police work and had ample financial resources.

As president of the Mars Candy Company, a company he founded, River Forest resident Franklin "Frank" Mars had substantial wealth. Taught candy making by his mother when he was a



*Frank C. Mars, founder of Mars, Incorporated, circa 1920*

child in Minnesota, by the time he built his new factory in Chicago's Galewood neighborhood in 1928 and moved into his River Forest mansion at 930 Ashland Avenue, his company's Milky Way chocolate bar was being sold throughout the world.

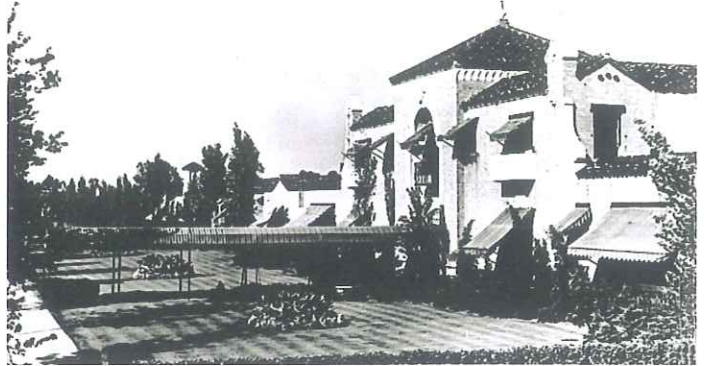

*The state-of-the-art Mars candy factory at 2019 N. Oak Park Ave. in 1929, shortly after it opened. The factory is scheduled to close in 2024. Planning is underway to determine what to do with the property.*

Frank had two avocations: horses and police work. Horses occupied his time whenever he visited his Milky Way Farms in Pulaski, Tennessee. Police work provided him with a civic-minded diversion when at home in River Forest. Well known in the community for his fascination with police work-- he was even named Honorary Captain of the Oak Park Police Department-- it was natural that Jerry's and Mars's interests would intersect.

Mars's new candy plant was state of the art and had a well-equipped maintenance and engineering shop. Eager to contribute to Jerry's vision, Mars opened access to these resources for Jerry.

By the time he applied for a patent on January 31, 1934, Jerry had clearly defined a problem and presented a unique solution. When he was awarded patent 1,991,101 on February 12, 1935, the US Patent Office demonstrated that they agreed.

Frank Mars would never know the extent to which Jerry's invention would impact the world. Mars died in April 1934. With Franklin's wife, Ethel, as an investor, development and sale of the light continued.

Jerry retired from the Oak Park Police Department in 1934, the same year that "The Light From Mars" made its debut. He now had a company to run.



# Root, Root, Root for the Home Team-- and for Your Family and Friends!

by Frank Lipo, Executive Director

Life slows down a bit in the heat of late summer, including on the dusty baseball diamonds in our local parks and schools, packed recently with newbies learning the nuances of T-ball, serious high school athletes playing on their respective baseball and softball teams, and middle-aged folks playing catch or hitting fungos with their kids.

Baseball is truly a rite of spring and early summer, bringing families and friends together with fierce



The Oak Park Cardinals, c. 1947. Ray Brennock is seated at the far left in the second row.

competitions, goofy team nicknames, and a post-game treat of fruit or junk food for the younger players or a few cold ones at a team sponsor's bar for the adults, win or lose.

But for some folks devoted participation in our varied recreational baseball and softball leagues, usually run by local park districts, keeps games going from early spring to late fall and demonstrates that friendships and camaraderie inspire many players just as much as the love of a big hit, a diving stop, or an inning-ending strikeout when the opponent is threatening to tie it up late in a game.

River Forest resident Therese Brennock, a staff member at Oak Park River Forest High School for more than 40 years, recently donated many team photos and a trophy that tell this recurring story of our local love affair with baseball and softball that brings the generations together across decades.

While cleaning out the old family home on South Kenilworth in Oak Park and preparing it to be sold, Brennock and her siblings came

across some family heirlooms related to the semi-pro and recreational baseball played by her father Raymond and her brother Matthew—and the bond they shared on local diamonds with each other and friends and teammates.

Her late father was a founder of the Oak Park Cardinals, a semi-pro team organized soon after he graduated from OPRF High School in 1947. Playing their home games at Rehm Park as part of the Columbus Park League, the players finished second in the league in the team's inaugural year. The popular semi-pro network saw fierce battles between Chicago neighborhood teams and suburban teams battling for municipal pride. (For more about the semi-pro circuit see "Oak Park's Field of Dreams was Located in Berwyn a Century Ago," *History Matters*, Summer-Fall 2021.)

The love of baseball was passed down in the family. Brennock's dad and her late brother Matt, a 1980 OPRF graduate, organized the Killer Smelts in 1987 for the Park District of Oak Park recreational league. Father and son bonded over strategy and camaraderie at Ridgeland Common and other local parks, with Ray soon sporting a shirt labeled "Head Smelt."

Therese Brennock, herself a 1977 graduate of OPRF and board member of the OPRF High School Alumni Association, has a keen sense of history and wanted this slice of family and community story represented in her local history museum. 



The Killer Smelts, c. 1987. Ray Brennock is kneeling on the far right in his "Head Smelt" T-shirt. His son Matt is standing behind him on the far right, second row.

*The Historical Society of Oak Park & River Forest Annual Members Meeting.*

## *Historical Society Welcomes New Officers to Board of Directors and Recognizes Contributions of Museum Volunteers*

On June 29th, The Historical Society of Oak Park and River Forest held its annual Members' Meeting at OPRF Museum. The evening included presentation of our three annual volunteer awards. Pictured below, from left: Mike Stewart received the Philander Barclay Award for his exemplary dedication to local history; Kurt Etchingham received the Faye Devine Award for outstanding volunteer service to the Historical Society; and Mary Ann Porucznik received the Carol Kelm Award for preservation of artifacts and archives related to the community's history. We congratulate them for their outstanding volunteer service.



The meeting also included the appointment of officers to lead our Board of Directors for the next two years. Pictured below, from left, are Treasurer Jack Norton; Vice President Wendy Daniels; President Fran Knechel; and Secretary Mary Boyaris.

Board President Peggy Tuck Sinko is stepping down after serving two successful terms as President. She will continue to hold a seat on the Board until 2024. Also stepping down is Kurt Etchingham, after serving three terms on the Board of Directors, including two as Vice President. Museum volunteer Frank FioRito was appointed as a new Board member.



## *"Tale of the Tombstones" Walk Headlines Coming Events for Fall*

Don't miss our annual *Tale of the Tombstones* Cemetery Walk on Sunday, October 15, where we will host a walking tour of Forest Home Cemetery and feature actors portraying a handful of the notable people laid to rest there. This year, our theme is celebrating the 150<sup>th</sup> anniversary of Oak Park and River Forest High School, and we will highlight people who have made their mark in education in our community. Advance registration is recommended, so visit our website [oprfmuseum.org](http://oprfmuseum.org) or call the museum at 708-848-6755 to purchase tickets today.

And please join us for these other exciting events happening at the museum soon. Visit our website at [oprfmuseum.org/events](http://oprfmuseum.org/events) for more information:

- Tuesday, September 12 at 6 p.m.- "The Life Cycle of Clothing," program by historian Erika Holst
- Thursday, September 28 at 7 p.m.- History Book Club meeting

- Thursday, September 14 at 7 p.m.- "Philander Barclay's Wax Cylinder Recordings," program on 19<sup>th</sup> and early 20<sup>th</sup> century sound recordings
- Thursday, September 21- Soft opening of OPRF Museum's new exhibit, *Ever Changing, Yet the Same: OPRF High School at 150*
- Wednesday, October 4- "Night at the Museum" Grand Opening of new OPRF High School exhibit
- Thursday, October 5- Program with Paula Fenza on the history of Forest Home Cemetery
- Wednesday, October 25 at 7 p.m.- Program with local historian Abby Schmelling on the history of Jewish Waldheim Cemetery
- Thursday, October 26 at 7 p.m.- History Book Club meeting
- Saturday, October 28 at 10 a.m.- Art Deco Sidewalk Tour of Central Oak Park



OAK PARK  
RIVER FOREST  
MUSEUM

P.O. Box 771, OAK PARK, IL 60303-0771

NONPROFIT ORG.  
U.S. POSTAGE PAID  
OAK PARK, IL.  
PERMIT NO. 420



Our new exhibit will include many examples of OPRFHS uniforms, jackets, jerseys, and other spirit wear from the school's rich history.

## OPRF Museum Joins the Celebration of Oak Park and River Forest High School's 150th Anniversary

OPRF Museum's newest exhibit, *Ever Changing, Yet the Same: OPRF High School at 150*, opens to the public September 21st. This soft opening, in time for Homecoming Weekend, will be followed by "A Night at the Museum" Grand Opening celebration on October 4 at 7 p.m. with refreshments and special guests. (Read the full story on front page.)

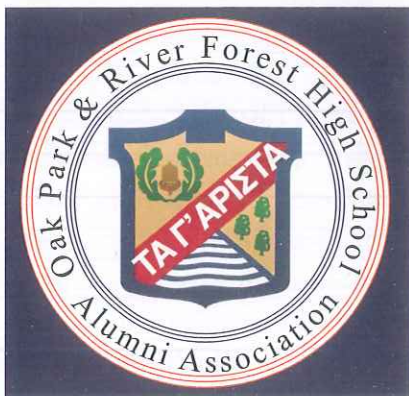

Lead sponsor of our new exhibit

Our exhibit is just part of the community-wide celebration of the high school's milestone anniversary. The High School Sesquicentennial Steering Committee is planning special events throughout the school year, beginning with Homecoming weekend September 22 through 24. Keep up to date with all the upcoming special events by scanning this QR code.



Sign up for weekly email updates about these events and other news at:  
[oprffhistorymatters@sbcglobal.net](mailto:oprffhistorymatters@sbcglobal.net) or phone (708) 848-6755